

SST Sight Glasses Stainless Steel

DN15 – DN150

SST Sight Glasses are ideally suited as reliable flow indicators for virtually all existing process media in either liquid or even gaseous state.

Modular Design

The Sight Glasses are available as per DIN standard (ANSI on request), with sight glass window plates made of Borosilicate acc. to DIN 7080.

The sturdy design bodies are made of stainless steel casting 1.4408 (CF-8M) or welded constructions made of 1.4404 (CF-3M).



SST-FD (flanged)
Body/cover CF-8M



SST-BW (butt welding ends)
Body CF-3M/cover CF-8M

Main Features

- Heavy-duty, proven construction - maintenance-free
- Horizontal or vertical installation, flange connection acc. to DIN PN16/40
- Standard drip ledge indicating even minute flows
- Large observation opening

 **Conformity according to European Pressure Equipment Directive 97/23/EC (PED)**

Options

- Metal reinforced glass plates
- Quartz glasses
- FEP glass protection sheet
- Visual flow indicator for gases (PTFE ribbon)

SST Sight Glasses Stainless Steel

Operating Conditions

- Temperature range from -40°C (-40°F) up to $+200^{\circ}\text{C}$ ($+392^{\circ}\text{F}$)
- Pressure range from 1mbar (0.01 psi) up to 16 bar (232 psi)

Testing / Marking

- Pressure- and tightness testing acc. to EN 12266-1, leakage rate A, resp. API 598.
- Marking of valves on body and name plate acc. to EN 19.
- Material- resp. test certificates acc. to EN 10204-3.1/2.2/2.1

Technical Data

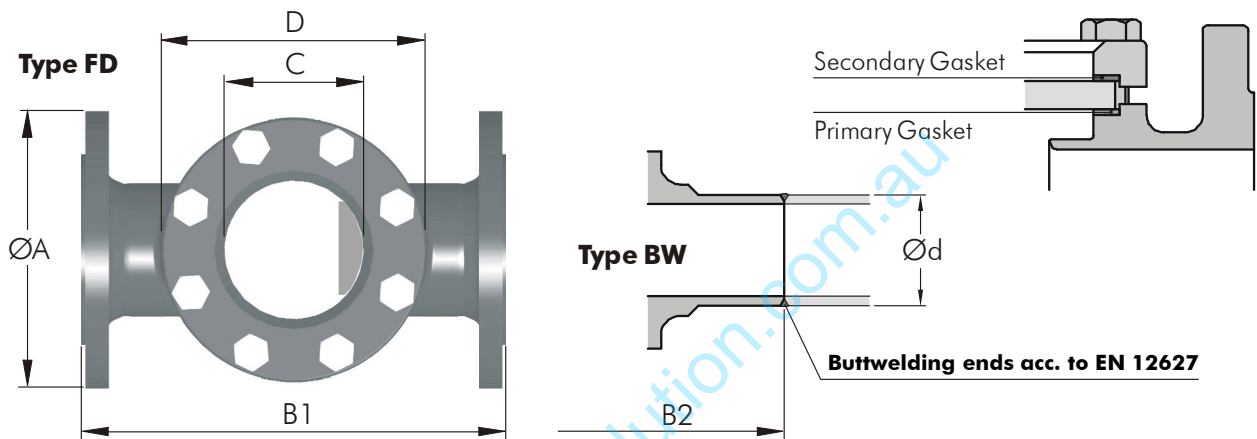

Standard Materials of Components

Body	Stainl. steel casting 1.4408 (CF-8M) for type FD, 1.4404 (CF-3MN) for type BW
Flange	Stainl. steel casting 1.4408 (CF-8M)
Glass Plate	Borosilicate 8488 acc. to DIN 7080
Gasket (primary)	PTFE-T (modified)
Gasket (second.)	C-4400 asbestos-free
Bolts	A2-70 1.4301

Dimensions in mm (lbs = kg x 2.2)

DN Size nom.	15	20	25	32	40	50	65	80	100	150
ØA	95	105	115	140	150	165	185	200	220	285
B1 FD	130	150	160	180	200	230	290	310	350	480
B2 BW ¹⁾	150	150	160	180	210	250	290	310	350	480
ØC	33	33	48	48	65	80	80	100	125	200
D	□70	□70	□85	□85	□110	□120	Ø175	Ø190	Ø210	Ø290
Ød ²⁾	21.3x2.0	26.9x2.3	33.7x2.6	42.4x2.6	48.3x2.6	60.3x2.9	76.1x2.9	88.9x3.2	114.3x3.6	168.3x4.5
ØGlass PN16	45x10	45x10	63x10	63x10	80x12	100x15	100x15	125x20	150x25	225x30
ØGlass PN40	45x10	45x10	63x15	63x15	80x20	100x25	100x25	125x25	150x30	-
kg appr. FD	2.6	3.4	4.7	6.9	7.4	9.7	17.5	25.0	38.0	55.0
kg appr. BW	1.5	1.8	2.6	3.1	3.9	5.1	10.0	15.5	25.0	39.5

B1 acc. to DIN EN 558-1 Range 1 ¹⁾ **B2** acc. to DIN EN 12982: DN15 – 50 Range S3, >DN50 Range S2 ²⁾ acc. to DIN 2633 Range 1
other materials or dimensions (e.g. ANSI flanges or lengths) upon request

SST Sight Glasses Stainless Steel

Options

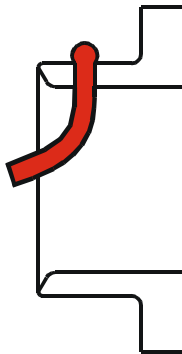

Visual Flow Indicator



Flanges acc. to ANSI 150lbs

PN40 (300lbs) Special Glass

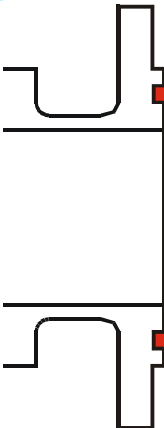
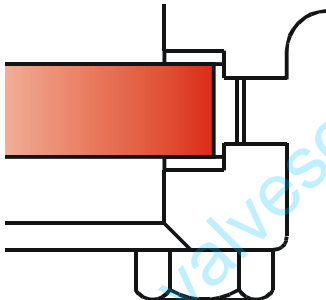

Flanges with Groove Form N acc. to DIN 2512

Metal-reinforced Glasses

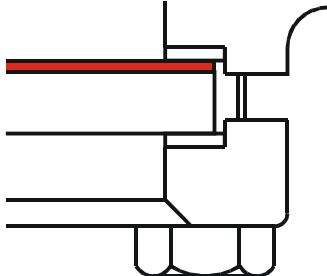
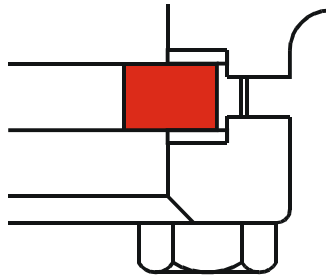

FEP Glass Protection Sheet

SST Sight Glasses Stainless Steel

Parts List

Sight Glass compl.

Standard Version (Picture showing DN 80 PN16, body FD flanged version)

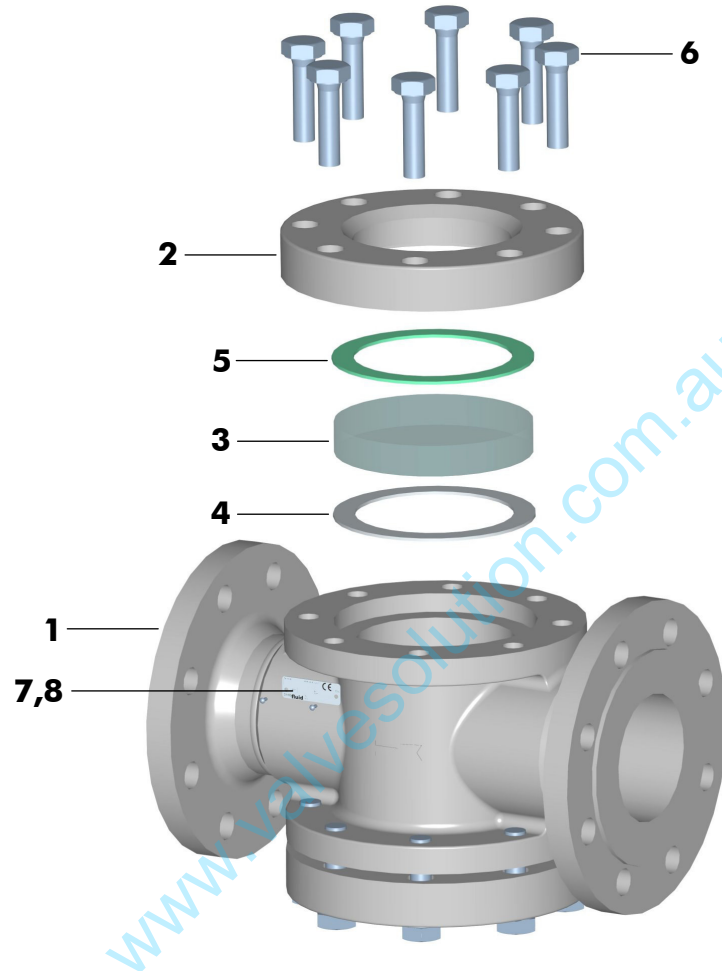

Item	Qty.	Description	Material	No.
1	1	Body *	CF-3M/SS316L	1.4404/1.4404
2	2	Flange	CF-8M	1.4408
3	2	Glass Plate DIN 7080	Borosilicate	8488
4	2	Gasket primary	PTFE-T	
5	2	Gasket secondary	C-4400	
6	16	Hex. Head Screw	A2-70	1.4310
7	1	Name Plate 42 x 14 CE	A2	1.4301
8	2	Hammer Screw 2.49 x 4.76	A2	1.4310

* Body welded, cons. of middle part CF-3M and flanges SS316L (1.4404 or 1.4435)
 DN15 – DN50: flanged body one-piece, casting CF-8M (1.4408), buttweld CF-3M (1.4404)



SST Sight Glasses Stainless Steel

Specification

Project-/Customer Data		Inquiry/Date: _____		Ref. SF	
Company:	_____	Contact Person:	_____	Phone:	_____
Address:	_____	Function:	_____	Fax:	_____
ZIP/Place:	_____	Department:	_____	E-mail:	_____
Project:	_____	Phone direct:	_____	Mobile:	_____

Operating Conditions

Media / Chemical Composition:

<input type="checkbox"/> liquid	<input type="checkbox"/> powdery	<input type="checkbox"/> crystallizing	<input type="checkbox"/> sticky	<input type="checkbox"/> Spec. Grav. ____
<input type="checkbox"/> gaseous	<input type="checkbox"/> Solids ____ %	<input type="checkbox"/> viscous	<input type="checkbox"/> Flow Velocity ____ m/s	
<input type="checkbox"/> abrasive	<input type="checkbox"/> Particle ____ mm	<input type="checkbox"/> Visc. ____ cp	<input type="checkbox"/> Flow Rate ____ m ³ /hr	

Pressure

max. ____ bar
min. ____ bar

Temperature

max. ____ °C
min. ____ °C

Mode

On/Off
 Flow Control
____ cycles/

Installation / Environment

horizontal
 vertical

Room dry
 Room humid
 outdoor

Remarks: _____

SST Product Code

Specification of a complete Sight Glass SST Series

Product code	Nom. size	Flange conn.	Type	Body	Glass plate	Options
SST	DN50	PN16	FD	G15	Gb	
	DN15 - 150 1/2" - 6"	PN16 PN40 ANSI150# ANSI300# JIS 10K	FD Flanged BW Buttweld	G15 CF-8M G14 CF-3M	Gb Glass plate PN16 Gb40 Glass plate PN40 Gr reinforced glass Gq Quartz glass	Gf FEP prot. sheet Op visual flow ind.